

IST-2001-33127

**SciX**

Open, self organising repository for scientific  
information exchange

## **D1: Scientific Publishing: As-Is Business and Information Model**

Responsible author: Bo-Christer Björk  
Co-authors: Turid Hedlund, Tomas Gustafsson

Access: public  
Version: 1.0  
Date: 30-Sept-02

## EXECUTIVE SUMMARY:

The scientific publishing process is currently undergoing the strongest paradigm shift since the invention of the printing press over 500 years ago. The current shift is caused by the advent of a new technology, the Internet, which radically changes the technological and economic infrastructure of the process. Already after only a few years it has strongly affected the behavior of all involved stakeholders. In particular the roles of two intermediaries, who stand between the original producers of the “product” (the scientific paper) and its consumers, are under question. These are the publishing companies and the scientific libraries.

This reports tries to paint a picture of what we currently know about the current situation. It does this in two separate sections. Firstly a brief **literature study** was done, to pinpoint what leading proponents from different “camps” are saying about the issues of the costs of the publication process. The first section also includes results from a limited empirical study of the current **prevalence of alternative publication modes**. In particular the aim was to estimate what fraction of published scientific journal titles is available in electronic form and for free. Based on two authoritative databases of periodicals 265 free online refereed journals were identified. The true number is probably much higher.

Secondly a formal **process model** was made of the scientific publishing process. This model tries to model the activities of all involved stakeholders, and to clarify them. The aim is to later use this model as the basis for empirical estimates of the costs of alternative business models.

The results of this first phase of the work provides a baseline from which to move forwards. For the conceptual work the literature study has highlighted the open research questions and the different answers given by adherents to the different camps. Also some of the currently most interesting initiatives have been investigated. The empirical study of the current actual prevalence of free E-journals is, as far as the authors understand, the first scientifically valid estimate of its kind and should be of interest as such. It has also been estimated in a way which allows a renewal of the estimate say two years from now, when SciX ends. The process model should in itself, be of interest to the scientific community. It also provides a good means to position very clearly in a broader picture the different technical demonstrators being developed in SciX. In addition the model will used as a basis for an empirical study of costs of different publishing models.

## RELEASE HISTORY

date	changes
Julj 14, 2002	First draft
August 30, 2002	Final version
September 26, 2002	Approved by partners, SciX template applied

**TABLE OF CONTENTS**

EXECUTIVE SUMMARY: .....	2
RELEASE HISTORY .....	3
TABLE OF CONTENTS .....	4
<b>1. A REVIEW OF THE FACTORS INVOLVED IN THE PARADIGM CHANGE FROM PRINT TO ELECTRONIC JOURNAL ARTICLES .....</b>	<b>6</b>
1.1 INTRODUCTION .....	6
1.2 THE FRAMEWORK OF SCHOLARLY COMMUNICATION .....	6
1.3 THE PUBLICATION PROCESS .....	8
1.4 ECONOMIC MODELS FOR SCHOLARLY PUBLISHING.....	11
1.5 NEW INITIATIVES.....	14
1.6 STUDY ON THE AVAILABILITY OF FREE ELECTRONIC REFEREED JOURNALS .....	15
1.7 CONCLUSIONS .....	16
<b>2. PROCESS MODEL OF THE SCIENTIFIC PUBLISHING LIFE-CYCLE .....</b>	<b>18</b>
2.1 AIM OF THE MODELLING EFFORT .....	18
2.2 SCOPE AND LIMITATIONS OF THE MODEL .....	18
2.3 MODELLING METHODOLOGY .....	19
2.4 OVERALL ORGANISATION OF THE MODEL .....	20
2.5 MODEL WALK-THROUGH.....	21
2.5.1 Do Research. Publish and Exploit the Results - Context Diagram .....	21
2.5.2 Do Research. Publish and Exploit the Results - breakdown.....	22
2.5.3 Do the Research.....	23
2.5.4 Publish and Study the Results .....	24
2.5.5 Exploit the Results.....	25
2.5.6 Publish the Results.....	26
2.5.7 Publish.....	27
2.5.8 Publish as Journal Article.....	28
2.5.9 Do General Publishing Activities .....	29
2.5.10 Do Journal-Specific Activities .....	30
2.5.11 Do Article-Specific Activities .....	31
2.5.12 Do Issue-Specific Activities .....	32
2.5.13 Archive and Index.....	33
2.5.14 Archive Electronic Copy.....	34
2.5.15 Manage Metadata.....	35
2.5.16 Study the Results .....	36
2.5.17 Find Out about Publication.....	37
2.5.18 Retrieve Publication.....	38
2.5.19 Inspect and Read Publication .....	39
2.5.20 References .....	40
<b>3. LITERATURE AND WEB-LINKS.....</b>	<b>42</b>
3.1 SCHOLARLY COMMUNICATION.....	42
3.2 ELECTRONIC JOURNALS, PUBLISHING AND TECHNICAL ISSUES .....	43

3.3	ELECTRONIC JOURNALS, ECONOMIC MODELS .....	44
3.4	ELECTRONIC PUBLISHING, LEGAL ISSUES .....	44
3.5	ELECTRONIC PUBLISHING, ARCHIVING .....	44
3.6	IMPACT FACTORS, CITATION INDEXING.....	45
3.7	USAGE STATISTICS .....	45
3.8	JOURNALS .....	45
3.9	PROJECTS, INITIATIVES AND DEBATES.....	46

## 1. A REVIEW OF THE FACTORS INVOLVED IN THE PARADIGM CHANGE FROM PRINT TO ELECTRONIC JOURNAL ARTICLES

### 1.1 INTRODUCTION

The relationship between scholarly communication and the publishing of research result is very close and important. The process of scholarly communication is according to O'Connor (2000) on one hand a simple one, but at its heart it is a complex one. The rapid growth of information technology in the form of fast networks, digital libraries and electronic publications has started a restructuring process during the last decade and also a debate on how to handle scholarly communication in the future. We can think of it as the old paradigm and a new paradigm, before and after the introduction of electronic publishing on a large scale.

Scholars have new ways of seeking information and producing and publishing their research results. Borgman (2000) makes the assumption that the relationship between scholarly communication and libraries in the form of digital libraries has become unbalanced with the advent of electronic publishing. The old paradigm closely involved the traditional role of the library performing and organising the distribution to clients and also taking care of the archiving function of print material. Now the communication process has changed, as scholars can exchange data with colleagues around the world quickly and in a convenient way without geographical restrictions and the role of the library becomes less obvious. However, the traditional journal article in print as well as in electronic form is still the essential element in disseminating research results and it is mainly the role of the libraries to handle subscriptions, licensing and access.

In this review we try to establish the structure and the factors involved in the paradigm change from traditional print publication to electronic publication of research results. The first section discusses the overall framework of scholarly communication, defining the actors, the universities, the publishers and the libraries. The second section identifies the publication process and the economic challenges. The third section deals with initiatives taken to change the old publication paradigm.

### 1.2 THE FRAMEWORK OF SCHOLARLY COMMUNICATION

The concept *scholarly communication* is by nature a continuing process, in some studies referred to as a social activity in a specific structural framework (Meadows 1998), a social communicative process of a research community (Kling & McKim 2000), or an activity that can be the object of bibliometric studies on citation behaviour in research articles (Borgman 1990). Lyman (1999) identifies as institutional parts in scholarly communication; research universities, publishers and libraries. The process of scholarly communication is in a simple form the process that records the research and scholarship of the world's universities. It is again complex in the relationships between authors, publishers, libraries and readers in a changing environment with new technological and communication media (O'Connor 2000).

The important product of scientific research, the publishing of research results also involves several actors and activities. Starting from the researcher in the university or research institute over editors, reviewers and publishers back to institutional libraries providing access to publications and indexing services and the researcher satisfying his information need by seeking information in the library. Lyman (1999) explains the culture where faculty members exchange information to create a sense of community in a cultural context as “gift exchange culture”. The same structure has been adapted by publishers to the publishing process of scholarly journals but in the form of a “market exchange culture”, with faculty authors as producers and libraries as consumers and the publisher as an intermediary. Thus creating a system where the academic gift economy subsidises the market economy (Borgman 2000).

*Digital libraries* can be seen as networked information systems providing content and access to information relevant for the user community. This is a more general view adopted at least by librarians. The view of the research or scholar is according to Borgman (2000) closer to that of a content collection. Scholars, publishers and librarians are all actors and stakeholders in the system where nobody at the time seems to have full control over the relationships. There are clear arguments for the promotion of electronic publishing over print journals for economic reasons, but also because of easy accessibility. On the other hand the important factors identified by Kling and McKim (1999) for an effective publication is: **publicity**, **trustworthiness** and **accessibility over time**. All three are elements that a print journal traditionally can provide while there has been a debate whether a free electronic publication or licensing policies can provide the same, specifically regarding accessibility over time. By-products, in the form of an electronic version to established print journals have been more easily accepted in the community of scholars. New publications that have started in electronic form only have not been as successful. The key question is according to Odlyzko (1997), whether electronic publications can be operated at a much lower cost than print journals. The need for successful economic models for electronic journals is evident.

National digital libraries have been established in several countries as a new initiative to handle the rapidly growing number of electronic information resources. Their goal is to be a service provider of a set of information resources, databases of text documents, and bibliographic references together with a set of tools and capabilities to locate, retrieve and utilise the available information resources (Borgman 2000). The information provided is to a great extent electronic journals from traditional publishers, but other contributors are universities and professional institutions. The users are mainly students, teachers, scholars and librarians.

**Scholarly journals** are by no means a new product. The first scientific journals *Journal des Scavants* in Paris as well as *Philosophical Transactions of the Royal Society of London* date as far back as 1665 (Rabow 2001). The publication process was undertaken by learned societies, a dominating pattern for several centuries. Scholarly journals have institutional and economic structures that are different from standard journals. The share of public finance in the process of producing, distributing and using research results is very high. The content of journals is provided, reviewed, edited and used by scholars themselves, which indicates that most stakeholders should benefit from keeping costs low.

There is an increasing number of peer reviewed journal titles starting in the last two centuries. Of these titles around 50% are active and online in July this year. See Table 1, and Figure 1.

*Table 1. Number of peer reviewed journal titles / starting year  
Data source: Ulrich's Periodicals Directory*

Starting year	No. of titles	Active online july 2002
1800-1850	103	53
1851-1900	598	335
1901-1950	2941	1549
1951-1960	2006	998
1961-1970	3075	1577
1971-1980	4667	2124
1981-1990	5412	2405
1991-2000	4775	2483

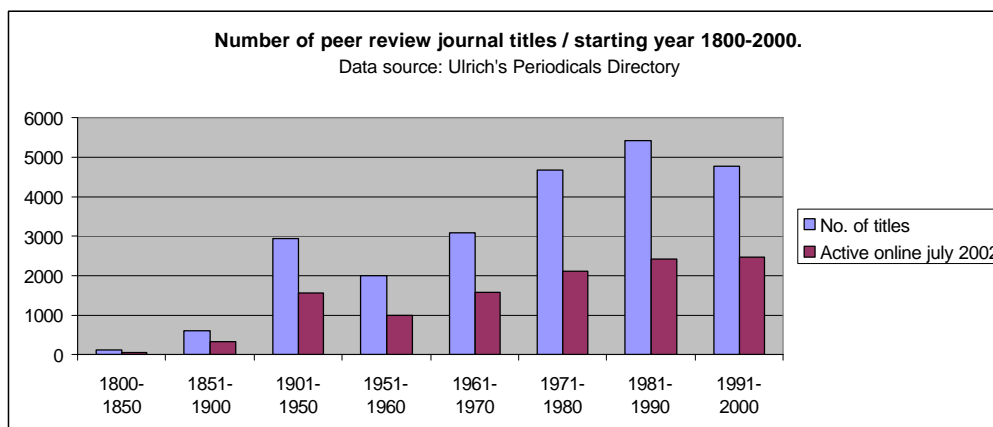

*Figure 1. Number of active online peer reviewed journal titles (July 2002) compared to all peer review titles / starting year. Data source: Ulrich's Periodicals Directory.*

The commercial aspects of scholarly publishing dates back to the twentieth century, with commercial publishers taking over the dominating role in journal publishing. However, the other activities, the production and the use of the information still remained publicly financed. Today we have an immense growth in new research fields as well as the number of journal articles produced. The publishing of new research results is a vital part of the activities in every research unit and also a mean to achieve merits and financing.

### 1.3 THE PUBLICATION PROCESS

The aims for producing a scientific journal article has remained quite unchanged over time. For the author the visibility of research results is of main interest, while the archival function and access to publicly financed research is of interest to the society.

The article serves three main functions (Rabow 2001):

- to give information
- to establish priority
- to act as a label for quality

A traditional print journal article fulfils the aims and functions described above.

The traditional certification control for the content of scientific journal articles is the peer review system, where the manuscript is passing through a refereeing process, by experts of the subject of the paper. The process is often carried out as "blind refereeing" where neither the reviewer nor the author knows the name of each other. The editor or the editorial board are conducting this process and it serves the purpose of sorting out low quality articles. The reviewing system also serves the author by returning probably valuable comments for improvements to the article. In Figure 2 we include typical instructions for how to prepare a referee report to an electronic refereed journal, "The Electronic Journal of Information Technology in Construction". Applying a refereeing process also generally adds to the reputation of the journal as a high standard publisher of research results. However, the peer review system is also very time consuming and postpones the actual release of the research results, crucially in fast moving disciplines, by several months up to one and a half year (Wells 1998/1999).

This document lists the questions the reviewers of the submitted papers are asked to answer in their review report. Making them public here should help the authors to improve the quality of their work prior to submitting to ITcon.

The reviewers are advised to COPY this text and PASTE it into their email programme and answer the questions.

1. General

- How relevant is your judgement?
  - very - this is close to my field of research.
  - quite - I follow the advances in the field.
  - average - quite familiar with some topics, not so familiar with others.
  - irrelevant - please assign to someone else.
- In a phrase, what is the substance of the paper?
- Is this work different from other previous or parallel efforts? If so, how?
- Is the English language correct and concise?
- Is the paper well organized? How can its organization be improved?
- Are the illustrations clear; do they support the paper.
- What is your recommendation to the editors?
  - accept as is,
  - requires minor revisions but does not need for another review,
  - requires major revision and another review,
  - reject.
- What are your recommendations to the author?

2. Related to the introduction

- Does the summary summarize or does it introduce the paper?
- Is the introduction repetitive with other similar efforts?
- Are the related or parallel efforts referenced?
- Is the problem well described?

3. Related to the core

- Do the authors explain the original aspects of their work?
- Are the criteria for the design or implementation clear? If it is an implementation, do the authors describe the platforms, libraries, and other environment that are essential for the implementation?
- Are the examples explained and clear?
- Can the success or failure of the effort be assessed?

4. Related to the conclusions

- Are the conclusions clear and conclusive. Are they supported in the paper?
- Do the authors succeed in proving the original hypothesis?
- Is there an objective discussion of the research results?

*Figure 2 Instructions for reviewers on how to prepare a referee report.  
Source: Electronic Journal of Information Technology in Construction*

The quality control of article format is done by the editor or the editorial board. But the archiving function for print journals is largely put on national or university libraries, which also take care of the distribution to users by displaying the journals in library catalogues, reference databases and reading rooms.

It is widely accepted that scholarly journals also should be available in electronic form. Whether this should be as a by-product to the print version or as an entirely electronic product is today a decision that is taken mostly by the publisher. In the future other publishing models, e.g., electronic scholarly journals published free or for a relatively low subscription price on the Internet might dominate.

The International Association of Scientific, Technical and Medical Publishers, cited in Rabow (2001) presented a proposal for scientific publishing in an electronic environment.

The following conclusions were made for all publications:

- fixation (the document should be firmly presented in some medium)
- accessibility (publicly accessible but not necessary for free)
- preservation (accessible and readable over time preferably in the same form and at the same address)
- control of version (bibliographical data should be added to every version)
- authenticity (all versions should be certified as authentic and be protected against change)
- identification (each document should have a "stable" identification code)

#### 1.4 ECONOMIC MODELS FOR SCHOLARLY PUBLISHING

The **pricing policies** for traditional journals published by commercial publishers have been causing serious discussions among the producers and users of information as well as the actual customers, the university libraries. "The Faustian bargain" (Rabow 2001) reveals the following structure:

- Research is publicly financed
- The publisher get content, peer-review and editorial work for free from the scholars
- The publishers acquire copyright to an article in exchange for publishing and distribution
- The libraries are publicly financed. They buy from the publishers to steadily rising prices the products of the scholars.

The market for scholarly publications does not work in a satisfactory way. The libraries pay large amounts of money for subscriptions or licenses to publishers but the real consumers of the provided information are the scholars and students in the university. Scholars are encouraged to publish in well-known journals. They see the importance of attracting readers but they do not initially have to worry about journal prices, accessibility or the overall economic structure of scholarly communication. Today the costs for rising journal subscription prices are put on the university in the form of a crisis in library budgets. The Ebsco Information Services, an agency specialised in subscription services to libraries, rates factors like currency exchange rates, increased number of pages and volumes, postage and handling costs, subscription cancellations and basic inflation as factors affecting serials prices, likewise the shift towards electronic delivery of information <http://www.ebsco.com/home/printsubs/priceproj.asp> . The crisis in serials prices is illustrated by a five-year journal price increase history based on subscriptions

by U.S. libraries 1998-2002. The increase in price for total titles ordered by research libraries during the five year period is 34,2%. See Table 2.

*Table 2. Five-year journal price increase history – U.S. research libraries ARL (Data source: Ebsco Information Services <http://www.ebsco.com/home/printsubs/history.pdf> )*

	1998 Avg. title price	1999 Avg. title price	2000 Avg. title price	2001 Avg. title price	2002 Avg. title price	% increase 1998-2002
US titles	\$240,34	\$261,61	\$284,83	\$309,75	\$334,20	39,05%
Non-US titles	\$597,27	\$641,28	\$688,75	\$730,88	\$778,73	30,38%
Total titles	\$360,99	\$389,94	\$421,36	\$452,10	\$484,46	34,20%

There exists no free market for scholarly journals since there is no price competition. Journal titles directed to a small segmented group of scholars are very common. The editions are small and therefore prices can be very high. The scholars wish to publish and the product is given away for free. The consumer again has small chances to choose a different product since a real competing product is lacking. The revenue of the publishers is high (Odlyzko 1997) since the initial product - the content is free and the development and value added costs are low.

Publishing models where scholars control the process have been proposed by Odlyzko (1997), Bot & Burgermeister (1998), Bot, Burgermeister & Roes (1998) and Ginsparg (1994, 1996). The Ginsparg model has been put into practice in the successful pre-print physics archive. In this model, traditional publishers of print or by-product electronic versions of scholarly journals have a serious competitor in the scholars themselves acting as producers and distributors of articles as well as being consumers of the information.

The traditional publisher's point of view is that this experiment will not work without subscription fees. The motivation is that switching to electronic format will only save about 30 percent of the costs of publishing, namely costs of printing and mailing (Odlyzko 1998). Borgman (2000) also stresses the fact that the working time that university professors put on editorial work is paid by the university and that it is also the institution that provides office space and computer equipment. Most of the cost savings in Odlyzko's model come from the elimination of the publisher's revenue. In studies by Odlyzko in (1995, 1997) and by King and Tenopir (1998), the estimate of the publishers revenue per article would amount to \$4000, (e.g. the total revenue from sales of a journal divided by the number of articles in the journal). This is a median revenue figure of an extremely disperse sample. The lack of price competition in the market for scholarly journals was evident in the studies. Neither could the differences in price be explained by differences in quality. The most important quality factor for scholars being the quality of the material published. But in the study by Odlyzko (1995) there was no strong correlation between price and quality of content. Even prestigious journals could be published with relatively low costs.

Over a period of twenty years (1975-1995) the number of scientific scholarly journals published in the United States has increased by estimated 62%, from 4.170 to 6.771. However the change

in size and frequency of publishing is also substantial. See Table 3. Increasing the number of articles published per journal title is cost effective and is a complement to the trend to publish new titles (Tenopir and King 2000).

*Table 3. Scholarly journal publishing parameters: 1975 and 1995 (Source: Tenopir and King 2000, p. 268).*

Cost model parameter	Year	
	1975	1995
No. of issues	6,5	8,3
No. of articles / title	85	123
No. of manuscripts submitted	90	205
No. of article pages	630	1.439
No. of special graphics pages	114	260
No. of total pages	820	1.728
No. of subscriptions (median)	2900	1900

In an article, Tenopir and King (1998) summarise the costs of publishing scholarly journals. The study is based on research data and in-dept cost studies from several decades, thus providing trends concerning scientific scholarly journals. It also establishes costs, common respectively unique to electronic and print publishing. However the information about costs relates back to 1995 journal averages, so the study does not cover the cost and price level of today.

The authors identify five publishing components:

- Article processing (manuscript processing, editing, composition etc.)
- Non-article processing (tables-of content, letters, book reviews, covers etc.)
- Reproduction (printing, binding etc.)
- Distribution (wrapping, labelling, sorting, mailing, subscription maintenance etc.)
- Support (marketing, administration, finance etc.)

Publishing electronically according to Tenopir and King (1998) saves the cost of reproduction and distribution, some costs associated with paper issues and non-article processing of issue covers etc. The authors find that the savings to subscribers (ignoring additional electronic related costs) would not be very great. Value-added features that could be added to totally electronic journals will add additional costs.

To the economics of publishing, legal rights, such as intellectual property rights are highly important. The publishers would benefit from reforms of legislation that would ensure them more control over intellectual property. The now quite common online posting of pre-prints in physics also accepted by publishers in this field is not considered as a favourable practice by journals in all of the other fields.

Kirby (1997) compares subscription prices for libraries of mathematics journals and his findings indicate a price range per page from \$0,08 to \$1,53. Three of the highest quality mathematics journals, ranked by Kirby; *Inventiones*, *Annals of Mathematics*, and *Journal of the AMS* (American Mathematical Society), range in price/page from \$0,15 to \$1,10 The lowest priced

journals tend to be published by universities or societies (AMS, Association for Symbolic Logic, SIAM), and the highest priced are those published by commercial publishers (e.g. Springer, Elsevier). There seems to be no correlation between price and quality.

Debates about scholarly electronic publishing involve several factors that influence how people create, use, seek and acquire information. There is an interaction of technological, sociological, economic, political and cultural factors, all important to the forming of the complete picture of the problems attached to electronic publishing. The models created by Odlyzko and others concentrate on the distribution of content, as it is produced, not on the whole process of continuity of access to scholarly information. The preservation point of view, where libraries have an essential role, is not present in the models (Borgman 2000).

What is the reason for scholars to continue publishing in traditional print journals?

The incentive seems to be mainly the prestige attached to them. They have no incentive to dismantle the current system since to submit papers to such journals cost them nothing and it also costs them nothing to have their library buy the journals or buy access to the journals. This has to do with the budgeting and financial structure of the university faculties and the university libraries, and until the system is modified and costs of library subscriptions is made clear to faculty members the trend will probably not change.

## 1.5 NEW INITIATIVES

Some of the more significant trends in free online scholarly publication today have been summed up by Suber (2002) [ARL bimonthly report 220 <http://www.arl.org/newsltr/220/scholar.html>]. The trends indicate among others that more disciplines are setting up pre-print archives, following the example of the Los Alamos physics pre-print server <http://xxx.lanl.gov/>. See Ginsparg (1996). The Open Archives Initiative <http://www.openarchives.org/documents/index.html> “develops and promotes interoperability standards that aim to facilitate the efficient dissemination of content. The Open Archives Initiative has its roots in an effort to enhance access to e-print archives as a means of increasing the availability of scholarly communication.” But the term *Open* does not mean free or unlimited access to publications, rather openness in an architectural sense, defining machine interfaces and standards that enables access to content from a variety of providers (Lagoze, C., Van de Sompel, H. 2001).

The PubMed Central <http://www.pubmedcentral.com/> aims to fill the role of a global library in the digital age. It is not, and has no intention of becoming, a journal publisher. Its function is being a digital archive for life science journals providing access to journal articles on the PubMed Central server and also links to publishers' sites containing full text material. Access to PubMed Central is free and unrestricted. Maintaining open access serves as the best test of the durability and utility of the archive as technology changes over time.

BioMed Central <http://www.biomedcentral.com/default.asp> is a new initiative providing immediate free access to peer reviewed biomedical research. BioMed Central acts as an independent publishing house where research groups can start their own scientific journal

covering some specific area of biomedical research. The policy of BioMed Central is that all the original research articles in journals published by BioMed Central are immediately and permanently available online without charge or any other barriers to access.



Figure 3. BioMed Central. Source: <http://www.biomedcentral.com/>

Universities are also according to Suber supporting institutional self-archiving for their research faculty. The SPARC initiative <http://www.arl.org/sparc/home/index.asp?page=0> on institutional repositories, a response to market dysfunction in scholarly communication is one example of institutions actions to ensure the access to scholarly information. Creating archives however involves legal issues, such as copyright. In many areas publishers are keen on obtaining copyright to the articles published and also tend to reject articles that have been distributed in electronic form on pre-print servers or institutional web pages. Here the physics journals and the Los Alamos pre-print server have come to an agreement where pre-prints in most cases also later on are published as journal articles.

One of the trends mentioned by Suber is also the eagerness of publishers to experiment with new ways to access the content of journals. Some online content is provided free of charge, and experiments are going on finding ways to cover the costs of providing this kind of free access.

There is also a movement on the field of editors and researchers against the high and rising prices on subscriptions. Editors “declaration of independence” against publishers who limit access by charging very high subscription prices are becoming more common. More scholars are demanding that journals offer free online access to their contents. More white papers, task forces, projects, and initiatives are endorsing the Open Archives Initiative. The two most recent are the International Scholarly Communication Alliance

<http://www.topica.com/lists/fos-forum/read/message.html?mid=903374369&sort=d&start=78> ,

an initiative taken by research library organisations, and the Budapest Open Access Initiative, <http://www.soros.org/openaccess/>. More initiatives are acknowledging that progress requires the launch of new open-access journals. Both the Public Library of Science (PLoS) <http://www.publiibraryofscience.org/> and the Budapest Open Access Initiative (BOAI) have come to this conclusion.

## 1.6 STUDY ON THE AVAILABILITY OF FREE ELECTRONIC REFEREED JOURNALS

There are indications that more open-access peer-reviewed journals are emerging in almost all fields, most of them online-only. Exact figures or estimates on future trends are so far lacking. In the SciX project a study on the availability of free and refereed online journals will be

conducted.

For the study two large bibliographic databases for periodicals (The Ulrich's Periodicals database and ARL, The Association of Research Libraries) are being used. By using two different databases the researchers aim at getting as broad a basis as possible for the study. Generally these two databases are considered to be among the largest in use for periodicals.

For the study certain criteria were settled for the journals to fulfil. The following criteria are applied to the study:

- the journal has to be available in an online format. This does not necessarily indicate that there would not be a print version available, however, the main criterion is that there *is* an online version.
- the journal applies a referee procedure for the accepted articles.
- the journal has to be considered free of charge. This means that a journal, and *all* the articles in *all* the issues, is accessible free of charge. Some online journals have a policy to present most of their issues for free, but there is still a fee for accessing the newest issue(s). Furthermore, one criterion is that the reader should be able to access the journal without the necessity of registration or any kind of membership.
- the journal has to be active. The journal must have published articles at least a year and a half before the study was conducted. This course of action provides the “approved” journals to be truly active.

After executing suitable searches (by suitable is meant searches that fulfil the discussed criteria) on both the Ulrich's Periodicals database and the ARL, the results are added up. After checking that the search results do not overlap, i.e. no journal appears twice, each site for every journal is visited to check the availability of the articles. When visiting the site different information about the journal is recorded. That is information concerning field of science, year of publishing the first and the latest issue etc.

At this point of the study 265 journals, that fulfil the criteria, have been found. However, it is too soon to make any conclusions concerning for example the field of science, likewise the existing time for the journals is still missing. Nonetheless, this is most interesting information and therefore the study will focus on these matters in a later stage.

## 1.7 CONCLUSIONS

The shift towards electronic journals and the new paradigm in scholarly communication seems to be inevitable and inescapable, at least for some fields of science (life sciences, mathematics, computer science, physics etc.). These fields seem to be the “early adapters” of the new communication technology and the other fields will follow in due time. However, Kling and McKim (2000) conclude that there will be field differences in the adaptation process and that the “communicative plurality and communicative heterogeneity” are features in the scholarly landscape that will persist even though the use of electronic technologies will increase on the whole in society.

The general thought is that the price for publishing has to go down and that scholars in the future will have to be aware of the costs attached to the whole process of publishing refereed journal articles. The awareness would lead to a changed pattern in scholarly communication and to new economic models for electronic publishing. Of the actors identified in the process the “middlemen” (publishers and libraries) are most likely to have to change their roles and services to the scholarly community.

New efforts to describe and understand the scientific publishing life cycle and how it is affected by the Internet and the new communication technology will be necessary. Models are necessarily limited and simplifying and it is not possible to grasp the whole complex nature of scholarly communication through them. On the other hand they are able to provide means for cost and performance analysis of various alternatives in the publication process and will therefore be appreciated and needed in the future discussion.

Based on the study some summarising observations are:

- The number of Journals that also have an electronic version has risen dramatically during the last five years and is now approximately 50 % of all titles.
- Subscription prices have over the years risen more rapidly than inflation. According to the publishers this is due to rising costs. Looking at the characteristics of the market from a microeconomic viewpoint and at the profit levels of the leading commercial publishers a more likely cause is monopolistic practice.
- The number of free journals (which as a rule only appear electronically) is still rather small. In this study 265 such journals were indentified.
- Earlier most efforts for free journals or e-prints were based on individual efforts. The “mortality rate” of such endeavours has been high, often based on the difficulty in attracting enough good papers to reach the critical mass.
- Recently a number of new initiatives have arisen which rather than creating individual journals are trying to create infrastructures that enable groups of researchers to create new journals in a cost-effective way. This appears to be a very promising route and these efforts will be closely monitored during the SciX project.
- The process model of the current process (as-is model) helps in clarifying the overall process and will also provide a basis of the analysis of costs of alternative business models
- The list of currently active free electronic journals which has been compiled will help in both dissemination of information about SciX as well as in conduction possible surveys of experiences, cost data etc.

## 2. PROCESS MODEL OF THE SCIENTIFIC PUBLISHING LIFE-CYCLE

### 2.1 AIM OF THE MODELLING EFFORT

To understand the scientific publishing process and how it is affected by the Internet, in order to provide a basis for a cost and performance analysis of various alternative ways of organizing it.

### 2.2 SCOPE AND LIMITATIONS OF THE MODEL

The model explicitly includes the activities of all the stakeholders in the overall process, including the activities of the:

- **Researchers** who perform the research and write the publications
- **Publishers** who manage and carry out the actual publication process
- **Academics** who participate in the process as editors and reviewers
- **Libraries** who help archiving and in providing access to the publications
- **Bibliographic services** which facilitate the identification and retrieval of publications
- **Readers** who search for, retrieve and read publications
- **Practitioners** who implement the research results directly or indirectly

The current version of the model has some limitations which should be kept in mind. It only includes the publication and dissemination of research results in the form of publications that in the end can be printed out and studied on paper (irrespective of whether the publications are distributed on paper or electronically). Thus forms of communication such as oral communication, unstructured use of email and multimedia, which all are essential parts of the scientific knowledge management process, are out of scope. These could be added at a later stage, but would also add to the complexity of the model.

Also the model depicts publishing and value added services using both paper and electronic formats. Pure electronic or pure paper-based publishing could be described by subsets of the model. The same goes for free publishing on the web, which resembles traditional publishing, but where certain activities such as negotiating, keeping track of and invoicing subscriptions can be almost entirely left out.

The model includes some activities which would be typical for a scientific publisher publishing several journals, allowing for economies of scale. The activities of single-journal publishers could be described by a subset. The reason for including activities such as the general activities of a publisher is that these significantly influence the cost of running individual journals in the form of the general overhead costs that publishers add to the subscription prices.

In the model the unit of observation is the single publication, how it is written, edited, printed, distributed, archived, retrieved and read, and how eventually it may affect practice. The

viewpoint taken is life-cycle cost per publication. Thus at later stages all cost and time data which is collected will be translated to a per publication basis.

The aim is to clarify the process and to find a way of measuring the total life-cycle cost of a publication, since the objective of the reengineering efforts in the SciX project is to try to optimise the total life-cycle costs, rather than the cost of some particular stage. This is clearly in the interest of the public authorities that finance research as well as the researchers who are primary end users. Another aim of the modelling effort is to try to clarify the functions that the demonstrator parts of SciX tries to make more effective.

How easier access to scientific publications might influence the quality of later research and industrial practice, which use these publications as input, is clearly also an important issue, but such qualitative effects of a more efficient process are very difficult to model and even more difficult to measure, and have not been attempted in this model.

The same applies for the effect of the publishing on the careers of the authors, which is an important aspect for the choice of where to publish and has created a strong barrier for change to pure electronic journals from established “brand name” journals.

### 2.3 MODELLING METHODOLOGY

In order to read the model the reader needs some familiarity with the IDEF0 modelling methodology. The following short introduction is borrowed from Karhu [2000]. The IDEF0 method is a formal graphical modelling method. The main concepts are the activity and the flow. The flow can be used as input, output, control or mechanism. The presentation of the IDEF0 diagrams is hierarchical in a way that diagrams on lower levels are more detailed than those at top, Figure 1.

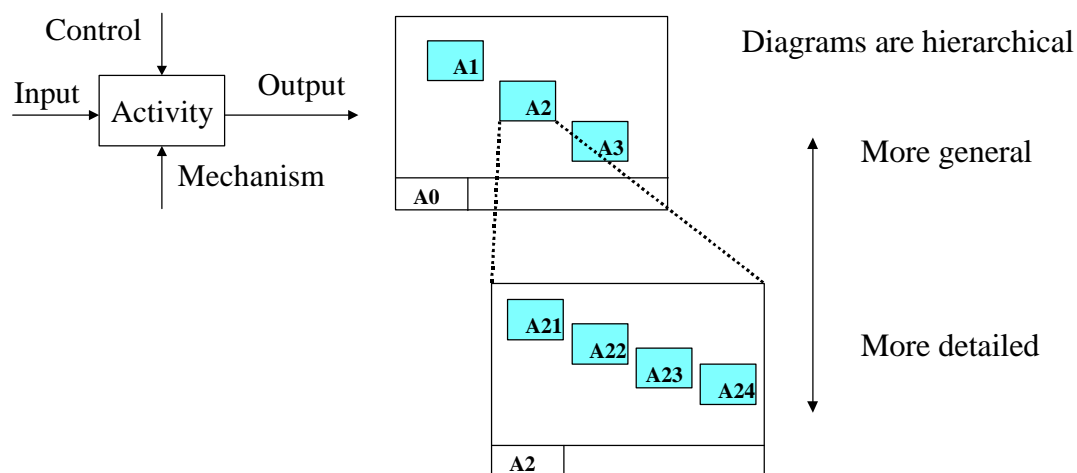

Figure 1. The basic concepts of the IDEF0 method.

In the SciX project HANKEN has used a particular tool called BPWin for making and editing the IDEF0 model. Compared to a simple drafting tool BPWin enhances the speed and consistency of the modelling work , especially for larger models and when changes are needed.

## 2.4 OVERALL ORGANISATION OF THE MODEL

The current version of the SPLC-model includes 19 separate diagrams, arranged in a hierarchy up to seven levels deep. There are typically three activity boxes on each diagram, although there are a couple of diagrams with more activities and some with only two. There is no logical reason for this, and IDEF0 recommends using up to six activities per diagram, but it was felt that models with three activities are easier to read and understand. There are altogether 58 activity boxes and more than 100 ICOMs.

In the following each diagram is explained separately. The diagrams are numbered using the standard IDEF0 numbering scheme, which helps keeping track of the hierarchical position of each diagram.

Note that the version of the model described below is a first draft and contain a number of minor errors as well as unresolved arrows. These will be corrected in later versions of the model, but due to the timetable of this deliverable it was felt that it was more important to show the model so that the other SciX partners have a chance to get acquainted with it.

## 2.5 MODEL WALK-THROUGH

### 2.5.1 DO RESEARCH. PUBLISH AND EXPLOIT THE RESULTS - CONTEXT DIAGRAM

This is the diagram for depicting the overall model, which traditionally is the starting node of all IDEF0 models, and which contains only one activity describing the overall process.

The philosophy of this diagram is to show how science can help in solving problems of everyday life by a combination of research (which creates scientific knowledge) with publishing, dissemination and exploitation activities (which ensures that results help in the advance of our collective body of knowledge). The one without the other is useless. The main stakeholders in the process are shown as mechanism arrows coming into the activity box from below, and the main drivers controlling the behaviour of the stakeholders are shown coming in from above. Note that from an academic viewpoint the main result is new scientific knowledge. From the viewpoint of society that funds research the most important outcome is improved performance of industry and society ( a better standard and quality of life).

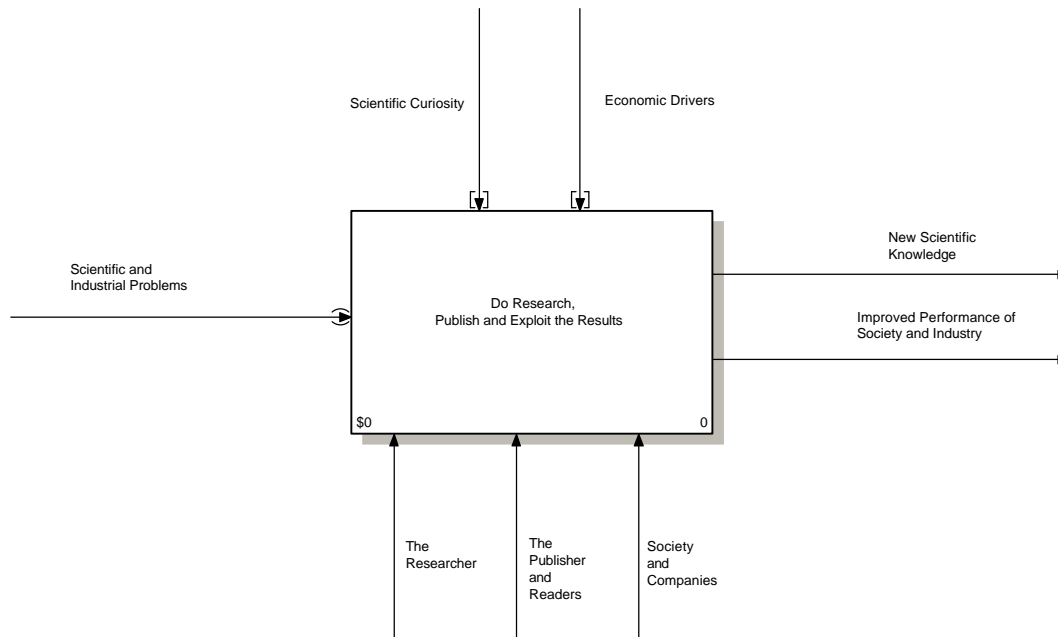
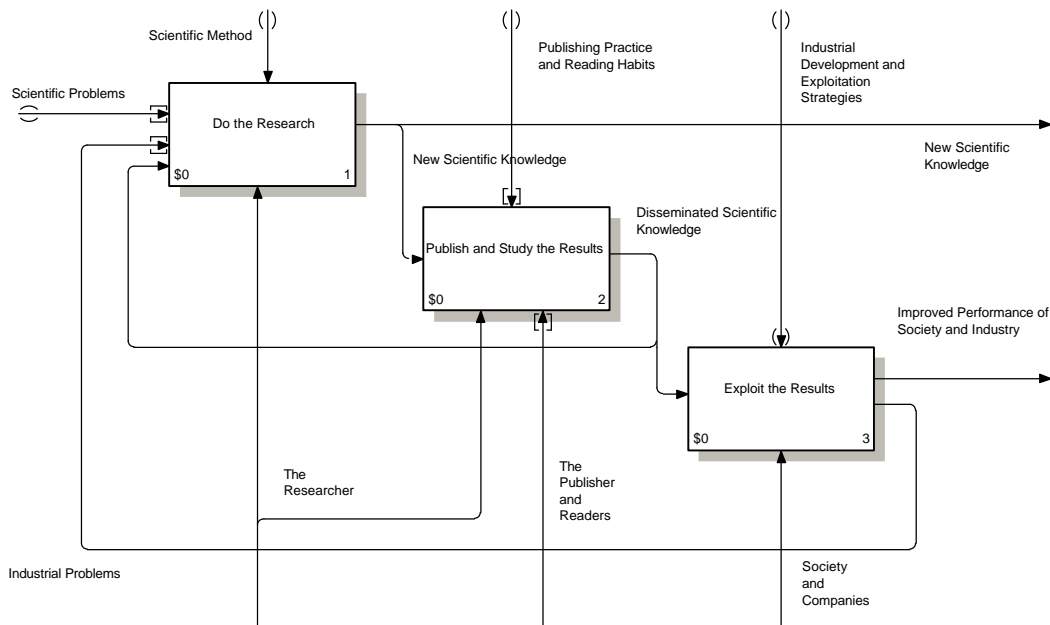

Diagram A-O Do Research. Publish and Exploit the Results, Context Diagram

### 2.5.2 DO RESEARCH. PUBLISH AND EXPLOIT THE RESULTS - BREAKDOWN

This diagram is crucial for understanding the life-cycle view adopted in this modelling effort. The whole life-cycle is seen as consisting of three separate stages. The ***Do the Research*** stage is probably the most expensive part, usually consisting of several man-months of work effort per resulting publication, but the one least affected by the reengineering efforts facilitated by the Internet. The ***Publish and Study the Results*** stage is the main object of study in this project, and the one which should be optimised. In the last stage, ***Exploit the Results***, the disseminated scientific knowledge is transformed to an improved performance of society and industry.



*Diagram AO Do Research. Publish and Exploit the Results, Breakdown*

### 2.5.3 DO THE RESEARCH

This diagram shows a highly simplified view of a typical research project. Note that one important feature of IDEF0 diagrams is that the consecutive activity boxes do not necessarily imply a strict order in time as in scheduling methods. Thus the activity *study earlier research* can go on after the other two activities have started. The important thing is that it provides input to these. Clearly this is only one possible way of looking at the research process. The reason for choosing this view is that it clearly distinguishes the *study earlier research* activity, which also is part of a later stage of the whole model. Here it is seen as providing input to the research that produces a publication, whereas the later stages of the model show how other researchers utilize the results for their own separate research projects. If this activity can be made more efficient, the overall productivity of the research can be increased.

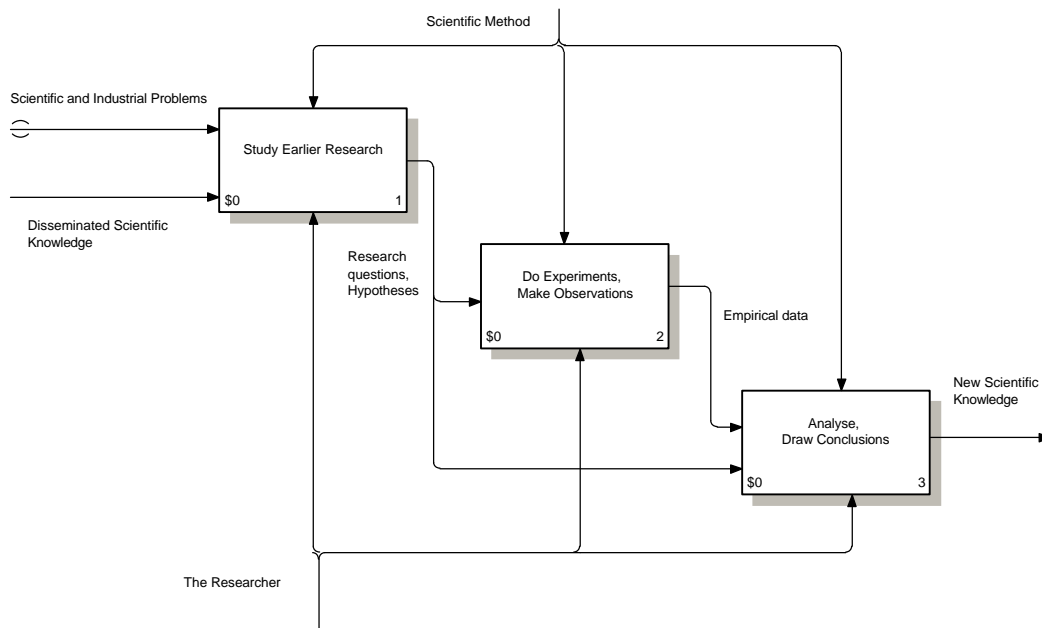

*Diagram A1 Do the Research*

### 2.5.4 PUBLISH AND STUDY THE RESULTS

This part of the model tries to clarify the dual nature of the publication process. From the perspective of the public bodies that to a large part finance research it is the efficiency of the total process, including both the production and “consumption” of publications, that should be optimised. The important thing is that in a life cycle analysis, the cost and efficiency of both the *Publish the Results* activity and the *Study the Results* activity are important. Optimising only one of these may lead to a sub optimal solution for the total process. Here Internet has changed the situation dramatically, as it has for any information goods that can be delivered in a digital format.

The end result of this sub model is called disseminated scientific knowledge, reflecting the viewpoint that scientific results which have been published, but which are not read by the intended readers are rather useless.

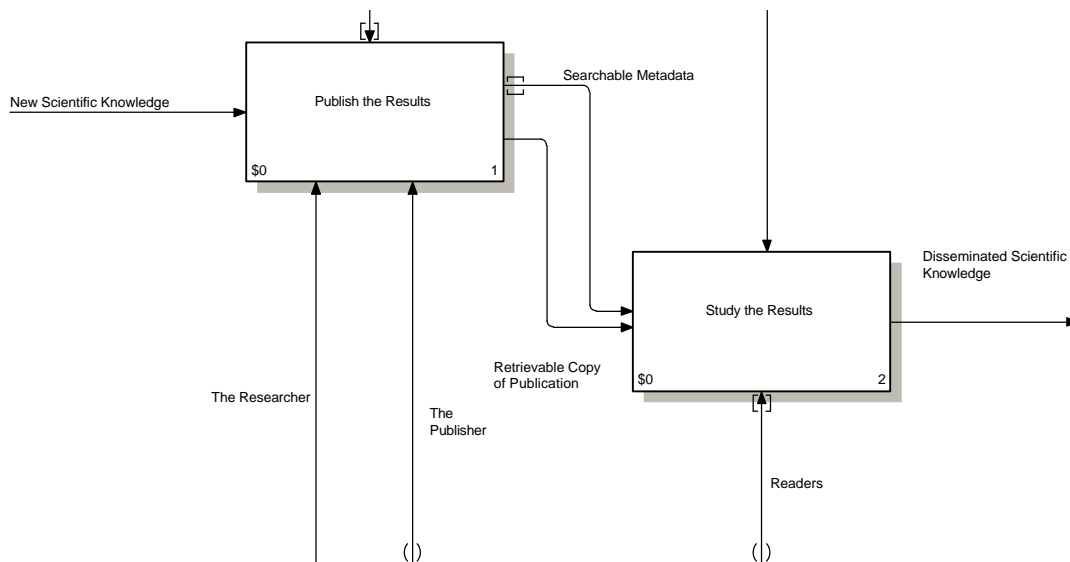
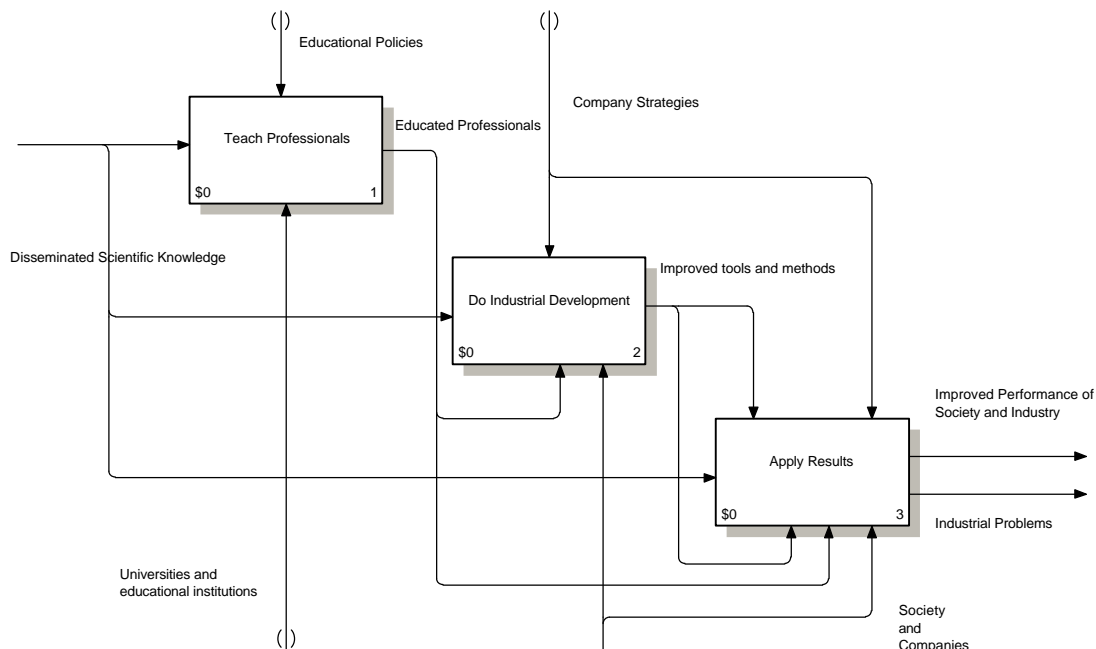

Diagram A2. Publish and Study the Results

### 2.5.5 EXPLOIT THE RESULTS

In the same way as the breakdown of A1, *Do Research*, this diagram is more of a contextual nature, since no further breakdown of this technology transfer process is attempted. It tries to show how disseminated scientific knowledge can be transferred by several parallel mechanisms into better industrial performance, new products and services and eventually a better quality of life. One of these mechanisms is education and training, which results in better trained professionals who go out into working life (i.e. medical doctors and engineers). There is a rather straightforward link between research and especially university education. A second mechanism is through commercial development work which translates research results into new products, services and working methods. A third mechanism is where practitioners read research publications and are directly affected by them.



### A3. Exploit the Results

## 2.5.6 PUBLISH THE RESULTS

This part of the model has been split up into three distinct activities, which to a large extent are carried out by different stakeholders. Based on the results of the research, the researcher writes a manuscript, which then in the next stage through a number of transformations is changed into a publication (on paper or electronic). The last activity is extremely important from a life-cycle viewpoint and involves the archival storage of the publication in research libraries all over the world as well as value-added services through bibliographic services etc.

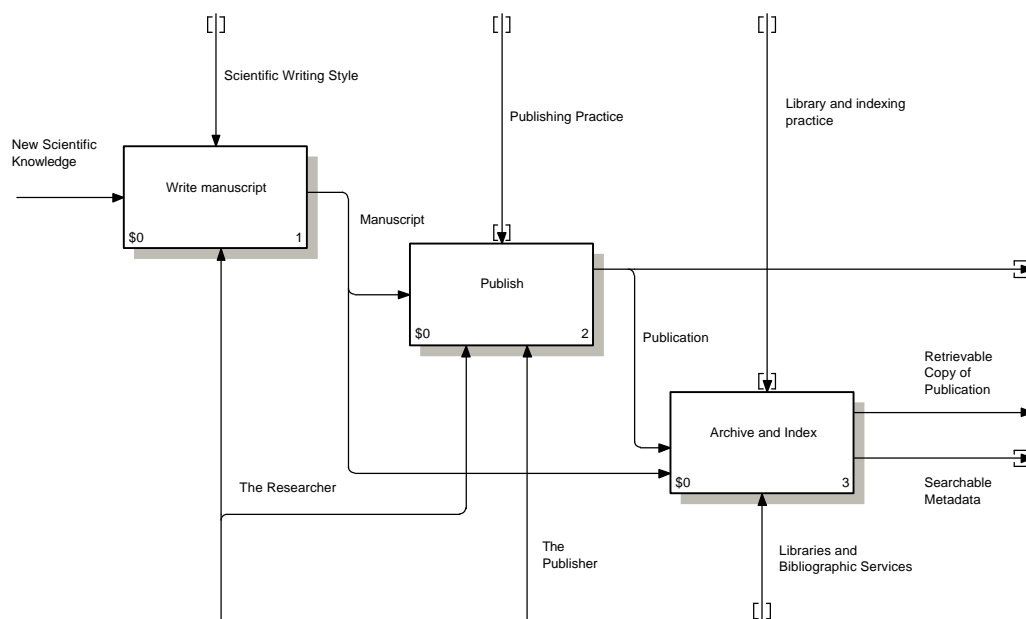
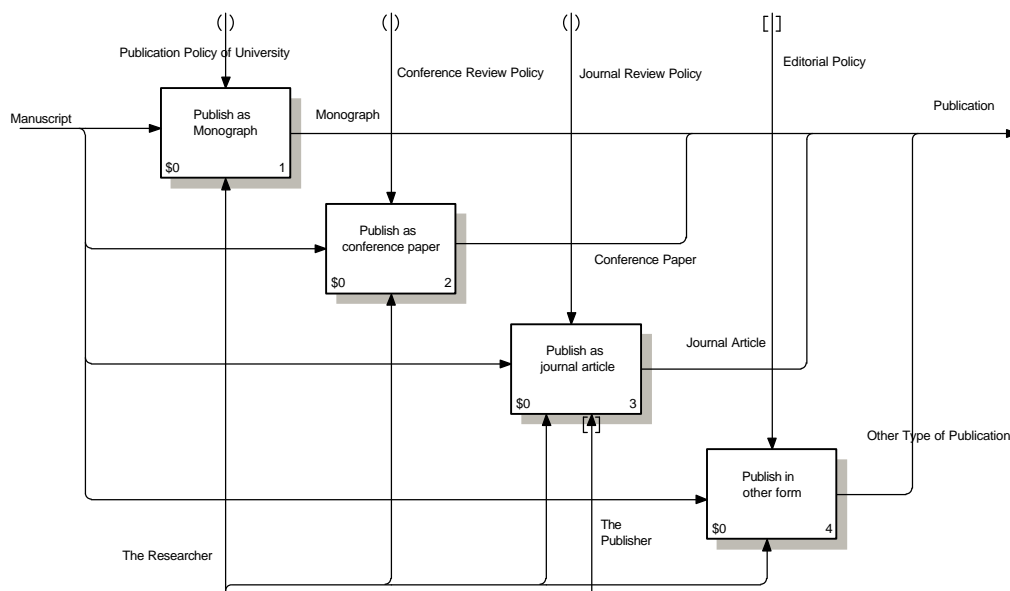

*Fig.A211 Publish the Results*

### 2.5.7 PUBLISH

At this stage the model is split into four parallel tracks which all take the generic “Manuscript” as input. The term monograph is in library science used to denote scientific publications which usually are published by the university of the researcher and which are not part of a scientific periodical journal or conference proceedings. Typical examples include working papers, research reports and Ph.D. theses. Conference papers are subjected to some sort of external review either for the abstract or the full paper, and are usually presented orally in addition to the printed version. Articles in scientific periodicals are subjected to rigorous peer review. It is important to note that periodicals articles have a much higher likelihood of being referenced in bibliographical services than the other types. Also journals are usually available by subscription whereas the access to monographs and conference proceedings is predominantly acquired on an individual basis. The fourth track involves publication of all other types, for instance as popularised articles targeted for an audience of non-academics.

Of these four only the publish as journal article has at this stage been further detailed. This is because of its relative importance in scientific publishing and also because the cost modelling effort will be concentrated there.



*Fig A212 Publish*

### 2.5.8 PUBLISH AS JOURNAL ARTICLE

This diagram may at first sight be difficult to understand. The idea is to show all the activities which are carried out by the publishing organisation, and thus have a direct cost implication for them. This is the reason for separating activities such as *Do general publishing activities*, *Do Journal-Specific Activities*. Both of these demand resources, which in a way cause overhead costs, which then are added on top of the basic variable costs caused by the processing of each individual article (in the activity *Do Article-Specific Activities*). For instance setting up and maintaining the IT-technical infrastructure for a portfolio of journals could be such an overhead causing item.

The main pipeline in the model is, however, the input arrow Manuscript, which directly enters the activity *Do article-specific Activities*. Issue specific activities have been separated out, because many sub-activities for traditional paper based journals are issue-specific.

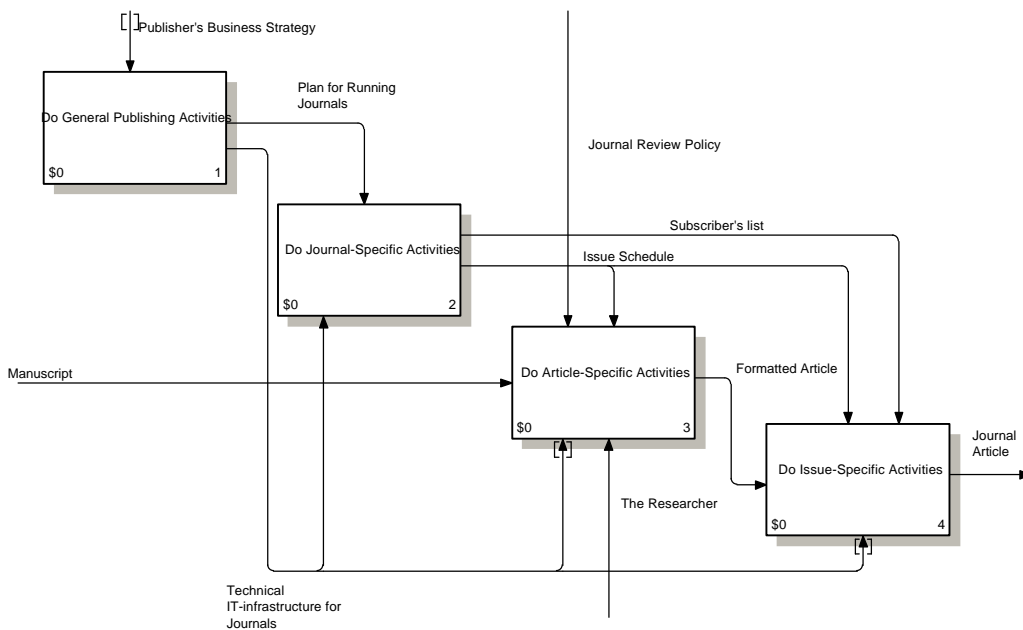
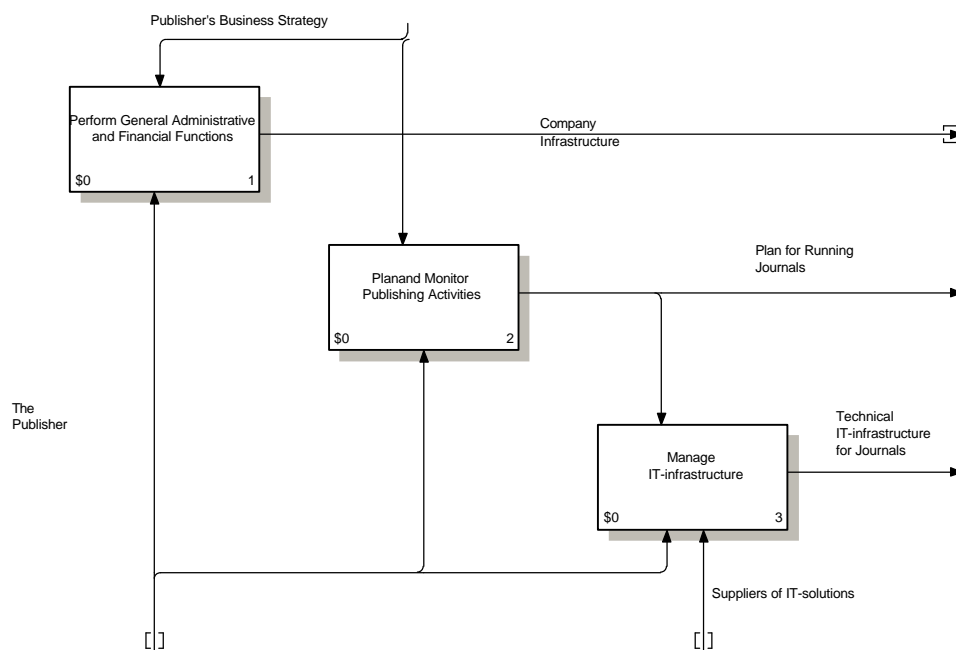

Diagram A2123 Publish as Journal Article

### 2.5.9 DO GENERAL PUBLISHING ACTIVITIES

General publishing activities are typical for most commercial publishers and such professional associations which publish several journals. Activities can include general management and financial functions as well as the setting up of the IT-technical structure for the production of journals (both on paper and the web). Typically such infrastructures are shared for a number of journals because of the savings due to the economies of scale.



*A21231 Do General Publishing Activities*

### 2.5.10 DO JOURNAL-SPECIFIC ACTIVITIES

Like many of the diagrams in this model, this model represents a choice of viewpoint. Here an important aspect is that commercial journals may spend a lot of money on marketing, and also on the management of subscribers (invoicing, setting up ways of checking access to electronic versions). For free electronic journals, the latter activity is almost none-existent. Note the output arrow issue schedule, which is later used as a control of issue-specific activities.

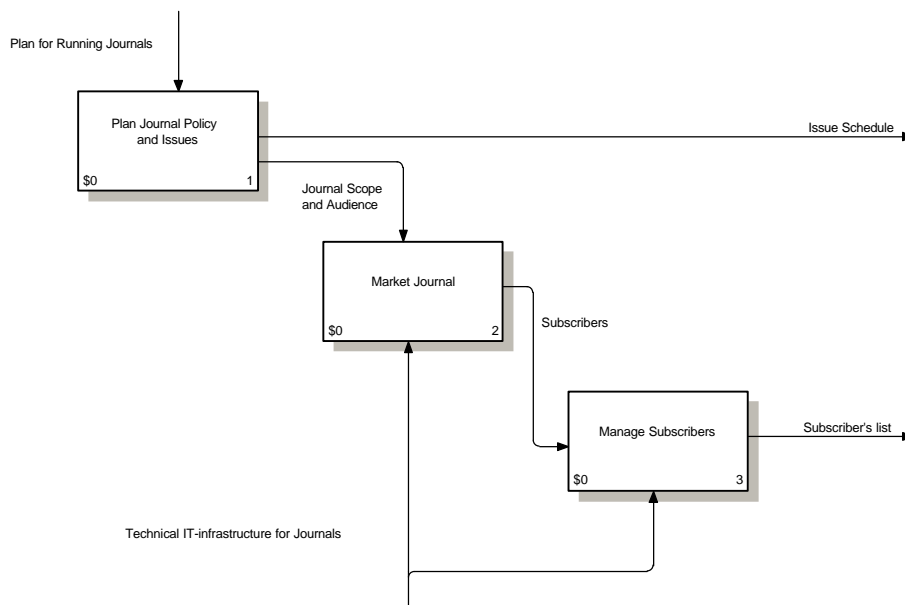

*Diagram A21232 Do Journal-Specific Activities*

### 2.5.11 DO ARTICLE-SPECIFIC ACTIVITIES

This diagram starts out by the review activities carried out as a co-operation between the editor, the researcher and anonymous peer academics. This activity demand resources but is usually not a cost item of significance for the publishers since reviewers usually work for free. This diagram includes a very significant activity which might escape modelling in many modelling exercises that focus solely on cost or the publisher's activities. Once an article is accepted for publishing, it enters an activity called *Queue for Publishing*, which typically takes from half a year to a year for traditional issue&paper-based journals (the worst case this author has experienced was three years). Waiting does not imply a direct cost, but there may be an important opportunity cost involved from the viewpoint of the researcher and society, since the results are poorly spread before the actual publishing. This opportunity cost is different for different domains of science. It might be low for the humanities but is usually higher in the STM (science, technology and medicine) domain. In particular this is the case for IT research, where developments are extremely fast.

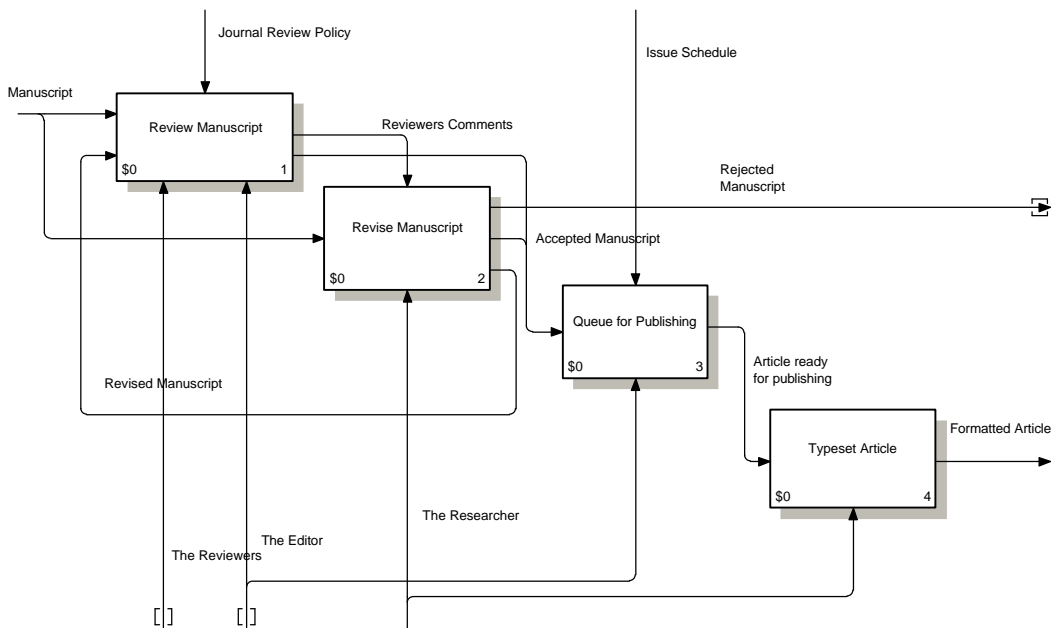
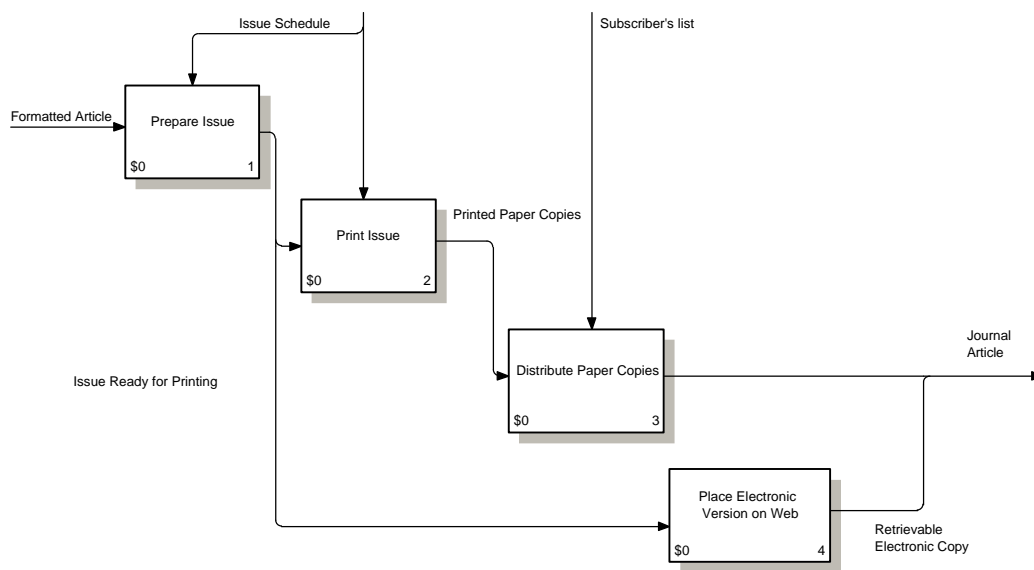

Diagram A21233 Do Article-Specific Activities

### 2.5.12 DO ISSUE-SPECIFIC ACTIVITIES

This part of the model depicts the activities which are typical for a traditional paper-based journal which also is produced as a parallel electronic version. The whole process is issue-centric, since issues are printed and mailed to subscribers. Note here how the outputs of journal-specific activities such as *issue schedule* and *subscriber list* work as controls for some of these activities.



*A21234 Do Issue-specific activities*

### 2.5.13 ARCHIVE AND INDEX

This is the part of the overall process which traditionally to a large part has been handled by research libraries, with public funding. Note also that from a cost viewpoint, we have hundreds of libraries from all over the world performing the same archiving function for each paper version of an article. The *archive electronic version* is indicated in the model, but this is one of the big question-marks at the moment. In theory it would be sufficient if the publisher maintains one integral web-version. What happens, however, if the publisher discontinues a journal or even goes out of business? How are older IT standards for documents handled (HTML or pdf 20 years from now)? There is scope for some arrangements for securing the long term archival of the electronic version. In the paper-centric model this hasn't been such a problem, since the libraries control the material they have once subscribed to and acquired.

The third part of the diagram shows the activities of an important value adding category of activities. Bibliographic services of different kinds take care of the metadata of publications and organise these in databases, allowing researchers the possibilities for useful bibliographic searches.

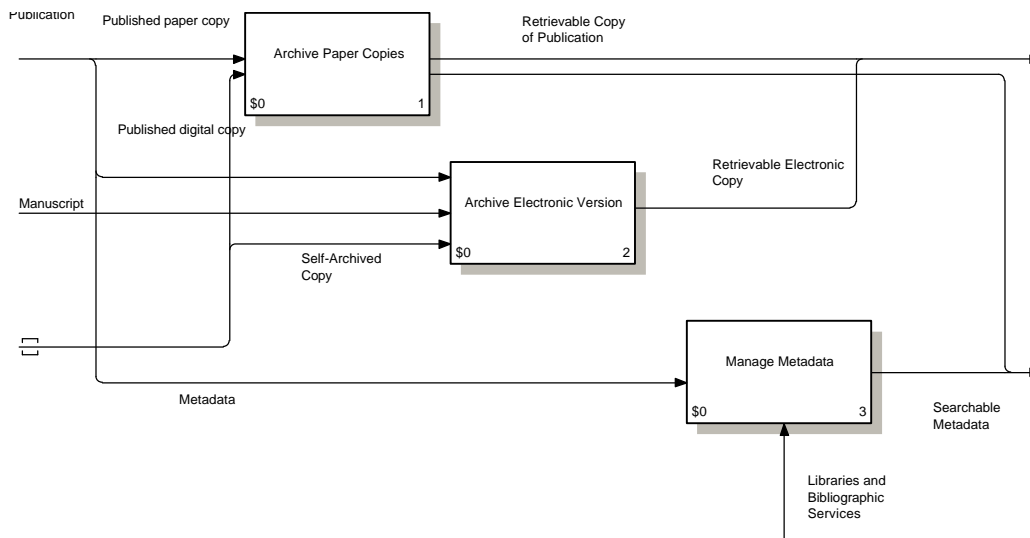

*Diagram A213 Archive and Index*

### 2.5.14 ARCHIVE ELECTRONIC COPY

This is an area where different new services are quickly emerging. One variation is for a centrally administrated service to offer access to full texts (i.e. EBSCO), as a rule on a commercial basis since such a service acts as a intermediary between the original publisher and the reader. Another interesting development is the self-administered full text service, as exemplified by the Los Alamos preprints server for particle physics. Such servers rely on the activity of authors to upload papers, and can achieve very low running costs due to a high degree of automation.

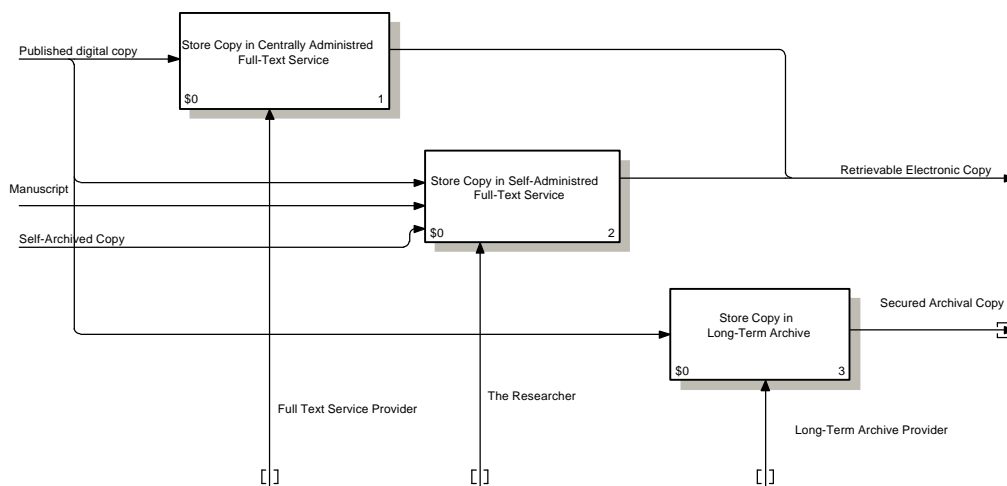

*Figure 2132 Archive Electronic Copy*

### 2.5.15 MANAGE METADATA

The split here seems to be almost identical as for full-text services. The difference is here in the third sub-activity, Run automated Meta-data Service, where automated web harvesting tools (a kind of search robot) find items which the authors have tagged using particular metadata standards.

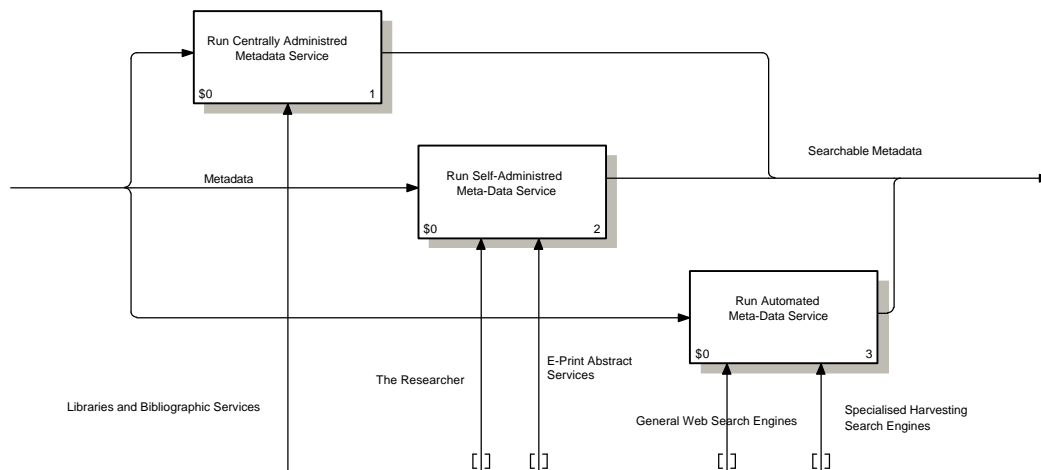

*A2133 Manage Metadata*

### 2.5.16 STUDY THE RESULTS

This diagram structures the activities of the readers of scientific activities. Note again that from a cost per publication the activities of individual readers all over the world and in different time periods should be summed up. The *Find out about Publication* activity results in the output *metadata of interesting publication* (including the location from which a paper or electronic version can be retrieved). This output is used as the control of the *retrieve publication* activity.

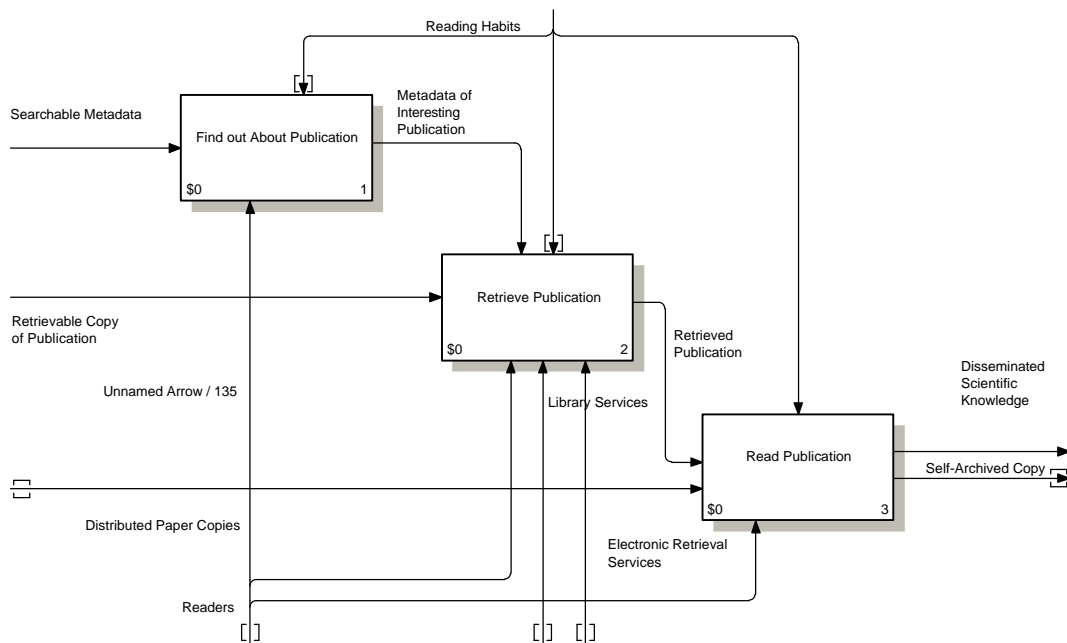

*Diagram A22 Study the Results*

### 2.5.17 FIND OUT ABOUT PUBLICATION

This activity is rather difficult to split up into alternative parallel options (for each identified article one of these is usually chosen). The first modelled option is a traditional bibliographic data base search, for instance using key words. **Receiving a hint from a third party** could be a hint from a colleague or a supervisor, or in today's world a hint from a software based alerting service. The important distinction is that the bibliographic search is triggered by the researcher himself (pull) whereas the hint is coming from the outside (push). **Notice reference in other publication** is very common. This is where it would be so convenient if all publications were for free on the Internet, because the retrieval would then only entail pressing a hyperlink. The last option **Remember existence of publication** is perhaps debatable.

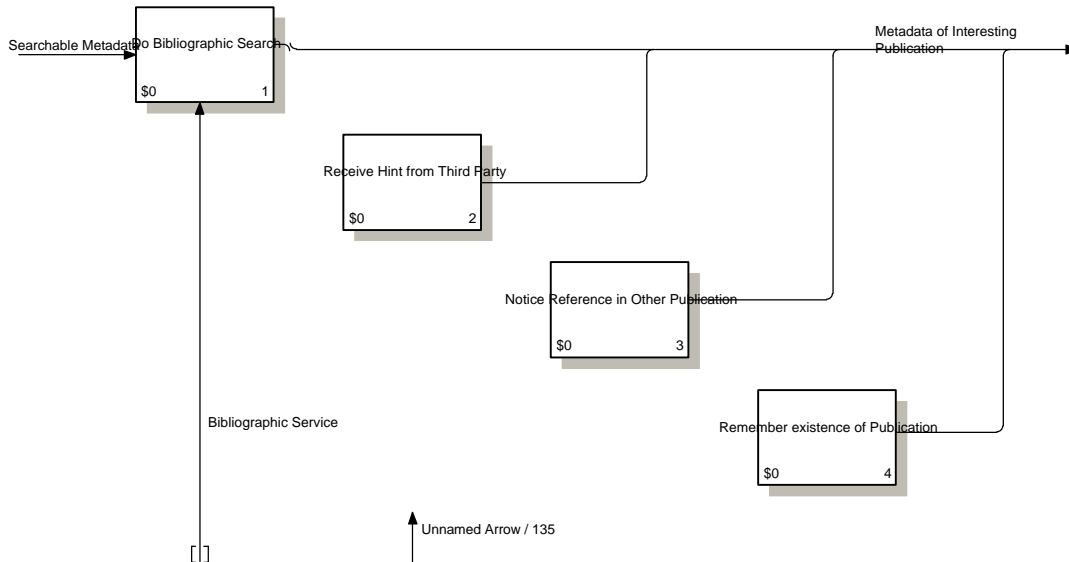

*Diagram A221 Find Out About Publication*

### 2.5.18 RETRIEVE PUBLICATION

The basic split has here been made between the retrieval of a copy of a paper publication and one in digital form. Although the two activities modelled here may look straightforward, they might become rather complex in reality. If for instance the organisation that the researcher belongs to doesn't subscribe to the journal in question, it might take quite a long time to obtain a copy of the article through some add on service for interlibrary loans or through a service for buying individual articles over the web. Many younger researchers have become lazy for retrieving paper-based copies at all, since so much is there on the web.

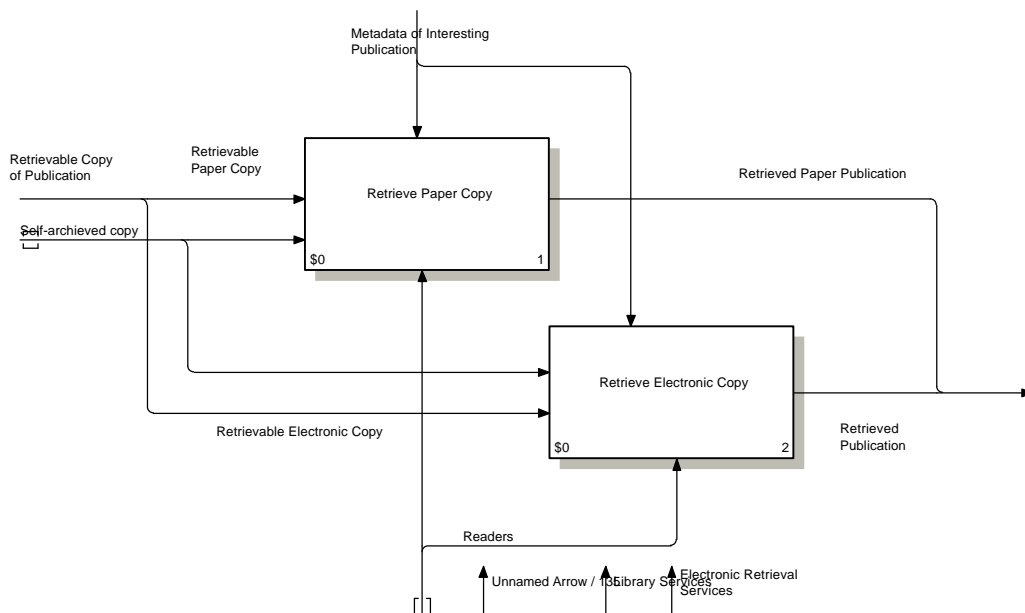
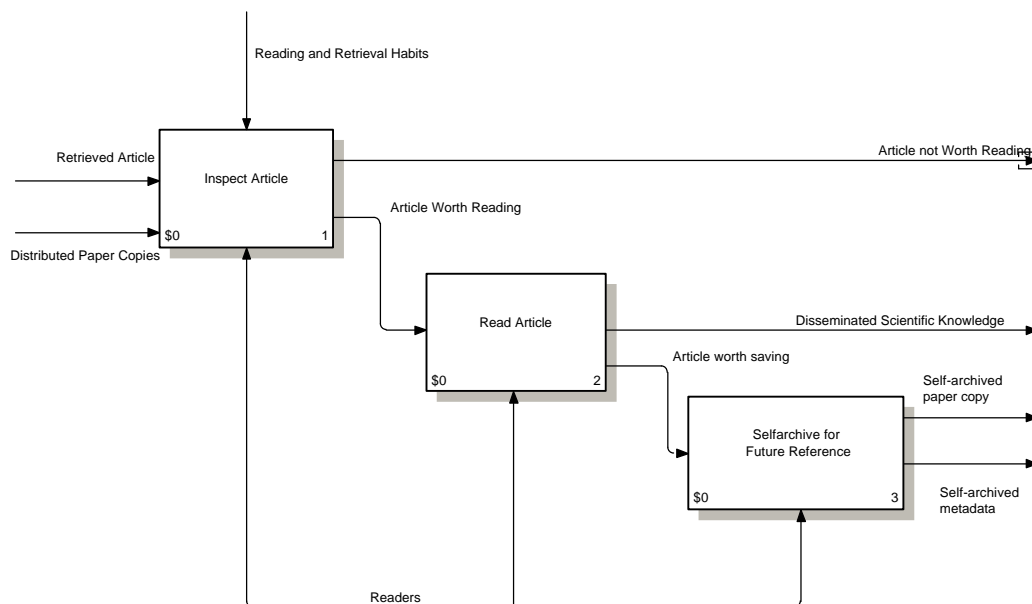

Diagram 223 Retrieve Publication

### 2.5.19 INSPECT AND READ PUBLICATION

This last diagram splits up the reading of an article into separate sub activities. Usually a researcher quickly scans a lot of material, without bothering to read a lot of it in detail. A separate activity for self-archiving interesting stuff has been included, since researchers often assemble large amounts of paper copies of the most interesting stuff in their own offices (or for electronic copies also lists of bookmarks).



*Diagram A223 Inspect and Read Publication*

## 2.5.20 REFERENCES

Borgman, C. (2000). *From Gutenberg to the global information infrastructure. Access to information in the networked world*. Cambridge, MA : MIT Press.

Borgman,C., ed. (1990). *Scholarly communication and bibliometrics*. Newbury Park, CA : Sage Publications.

Bot, M., Burgermeister, J. (1998). Costing Model for publishing an electronic journal. Price Waterhouse <http://cwis.kub.nl/~dbi/users/roes/erclaw/ejclwp6a.pdf>

Bot, M., Burgermeister, J., Roes, H. (1998). The cost of publishing an electronic journal: A general model and a case study. *D-lib magazine* Nov. 1998. <http://www.dlib.org/dlib/november98/11roes.html#duranceau>

Ginsparg, P. (1996) Winners and losers in the global research village <http://xxx.lanl.gov/blurb/pg96unesco.html>

Karhu (2000) A generic construction process modelling method  
PhD thesis, Royal Institute of Technology, Department of Construction Management and Economics, Availble as pdf file at, <http://www.indek.kth.se/publindex.html>

King, D., Tenopir, C. (1998). Economic cost models of Scientific scholarly journals. *ICSU Press Workshop*, Keble College, Oxford, UK. [Available at: <http://www.bodley.ox.ac.uk/icsu/kingppr.htm> ]

Kirby, R. (1997) Comparative prices of math journals. [ Available at: <http://math.berkeley.edu/~kirby/journals.html#prices> ]

Kling, R., McKim, G. (2000) Not just a matter of time: Field Differences and the shaping of electronic media in supporting scientific communication. *Journal of the American Society for Information Science* Vol. 51(14), pp. 1306-1320.

Kling, R., McKim, G. (1999) Scholarly communication and the continuum of electronic publishing. *Journal of the American Society for Information Science*. Vol. 50(9) pp. 890-906.

Lagoze, C., Van de Sompel, H. (2001) The Open Archives Initiative: Building a low barrier interoperability framework. *Joint Conference on Digital Libraries 2001*, Roanoke, VA. [Available at: <http://www.openarchives.org/documents/oai.pdf> ]

Lyman, P. (1999). Digital documents and the future of academic community. In R. Ekman and R. Quant, ed. *Technology and Scholarly Communication*. Berkeley: University of California Press.

Meadows, J. (1998) *Communicating research*. San Diego: Academic Press.

Odlyzko, A. (1997) The economics of electronic journals. *First Monday* Vol. 2(8)  
[http://www.firstmonday.dk/issues/issue2\\_8/odlyzko/](http://www.firstmonday.dk/issues/issue2_8/odlyzko/)

Odlyzko, A. (1995) Tragic loss or good riddance? The independent demise of traditional scholarly journals. *International Journal of Human-Computer Studies*. vol. 42, pp. 71-122. *Journal of Universal Computer Science* [Available at: <http://www.research.att.com/~amo> ]

Rabow, I. (2001). *Den vetenskapliga kommunikationsmarknaden - Elektronisk publicering. Slutrapport*, BIBSAM/KIB-projekt, Karolinska Institutets Bibliotek. [Available at: [http://kib.ki.se/info/proj/elec\\_pub/report\\_elec\\_publishing\\_se.html](http://kib.ki.se/info/proj/elec_pub/report_elec_publishing_se.html)]

Suber, P. (2002) Where does the free online scholarship movement stand today? *ARL* 220, Febr. 2002 [Available at: <http://www.arl.org/newsltr/220/scholar.html>]

Tenopir, C., King, D.W. (2000) *Towards electronic journals: Realities for scientists librarians and publishers*. Washington: SLA Publishing

Wells, A. (1998/1999). Exploring the development of the independent, electronic, scholarly journal. MSc in Information Studies U. Sheffield. [Available at: <http://panizzi.shef.ac.uk/elecdis/edl0001/> ]

### 3. LITERATURE AND WEB-LINKS

#### 3.1 SCHOLARLY COMMUNICATION

Borgman, C. 2000. Digital libraries and the continuum of scholarly communication. *Journal of Documentation* Vol. 56 (4)

Borgman, C. 2000. *From Gutenberg to the global information infrastructure: access to information in the networked world* Cambridge, MA: MIT Press

Butterworth, I. (Ed.) 1997 The impact of electronic publishing on the academic community. An International Workshop organized by the Academia Europaea and the Wenner-Gren Foundation

Wenner-Gren Center, Stockholm, 16-20 April 1997. Portland Press Books Catalogue [Available at: <http://tiepac.portlandpress.com>]

Ekman, R., Quandt, R.E. (Eds). 1999. Technology and scholarly communication. Berkeley: Univ. of California Press

Harter, S.P. 1997. Scholarly communication and the digital library: Problems and issues. *Journal of Digital Information* vol. 1(1) [Available at: <http://jodi.ecs.soton.ac.uk/Atricles/v01/i01/Harter/>]

Kling, R., Callahan, E. 2001. Research articles in scholarly electronic communication. *ARIST* vol. 37

Kling, R., McKim, G. 2000. Not just a matter of time: Field differences and the shaping of electronic media in supporting scientific communication. *Journal of the American Society for Information Science* vol. 51(14), pp. 1306-1320

Kling, R., McKim, G. 1999 Scholarly communication and the continuum of electronic publishing *Journal of the American Society for Information Science* vol. 50(9), pp. 890-906

Meadows, A.J. 1998 *Communicating research*. San Diego: Academic Press

O'Connor, S. 2000. Economic and intellectual value in existing and new paradigms of electronic scholarly communications *Library Hi Tech*, vol. 18 (1) pp. 37-45.

Odlyzko, A. 2000 The future of scientific communication. Access to publicly financed research: The global research village III, Amsterdam 2000. P. Wouters and P. Schroeder, eds., NIWI, 2000, pp. 273-278 [Available at: <http://www.dtc.umn.edu/~odlyzko/doc/recent.html>]

Odlyzko, A. 2001 The rapid evolution of scholarly communication. *Learned Publishing*, vol 15(1) pp. 7-19 [Available at: <http://www.alpsp.org.uk/journal.htm>]

Rabow, I. 2001 Den vetenskapliga kommunikationsmarknaden - Elektronisk publicering Slutrapport, BIBSAM/KIB-projekt, Karolinska Institutets Bibliotek [Available at: [http://kib.ki.se/info/proj/elec\\_pub/report\\_elec\\_publishing\\_se.html](http://kib.ki.se/info/proj/elec_pub/report_elec_publishing_se.html)]

Singer, P. 2000 When shall we be free? *The Journal of Electronic Publishing*, vol.6(2) [Available at: <http://www.press.umich.edu/jep/06-02/singer.html>]

Tenopir, C., King, D. 1998 Designing electronic journals with 30 years of lessons from print *The Journal of Electronic Publishing*, vol.4(2) [Available at: <http://www.press.umich.edu/jep/04-02/king.html>]

Wells, A. 1998/1999 Exploring the development of the independent, electronic, scholarly journal MSc in Information Studies U. Sheffield [Available at: <http://panizzi.shef.ac.uk/elecdis/ed1000/index.html>]

Wouters, P., Schröder, P. (Eds.) 2000 Access to publicly financed research, Background papers, NIWI Conferece proceedings [Available at: <http://www.minocw.nl/english/conferentie/deel1.pdf>]

### 3.2 ELECTRONIC JOURNALS, PUBLISHING AND TECHNICAL ISSUES

Risher, C.A., Rosenblatt, W.R. 1998. The Digital object identifier - An electronic publishing tool for the entire information community. *Serials review* Vol. 24 (3/4) pp. 12-20.

Tenopir, C., King, D. 2000. Towards electronic journals: Realities for scientists, librarians and publishers. Washington: SLA Publishing.

Walker, T.J. 1988. Free Internet access to traditional journals. *American Scientist*, vol. 86 Sept.-Oct.pp. 463-471.

Wells, A. 1998/1999. Exploring the development of the independent, electronic, scholarly journal MSc in Information Studies U. Sheffield [Available at: <http://panizzi.shef.ac.uk/elecdis/ed1000/index.html>]

Hibbits, B. 1997. E-journals, archives and knowledge networks: A commentary on Archie Zariski's defense of electronic law journals *First Monday* Vol. 2 (7) [Available at: [http://www.firstmonday.dk/issues/issue2\\_7/hibbits/index.html](http://www.firstmonday.dk/issues/issue2_7/hibbits/index.html)]

Suber, P. 2002. Where does the free online scholarship movement stand today? *ARL* 220, Febr. 2002 [Available at: <http://www.arl.org/newsltr/220/scholar.html>]

### 3.3 ELECTRONIC JOURNALS, ECONOMIC MODELS

Bot, M., Burgermeister, J. PriceWaterhouse Coopers 1998. Costing Model for publishing an electronic journal [Available at: <http://cwis.kub.nl/~dbi/users/roes/erclaw/ejclwp6a.pdf>]

Bot, M., Burgermeister, J., Roes, H. 1998. The cost of publishing an electronic journal: A general model and a case study *D-lib magazine* Nov. 1998 [Available at: <http://www.dlib.org/dlib/november98/11roes.html#duranceau>]

Jensen, M. 1998. Developing the appropriateness matrix. *The Journal of Electronic Publishing* vol. 4(1) [Available at: <http://www.press.umich.edu/jep/04-01/jensen.html> ]

Joseph, H. 2002 An economic model for web enhancements to a print journal. *The Journal of Electronic Publishing* [Available at: <http://www.press.umich.edu/jep/07-03/joseph.html>]

King, D., Tenopir, C. 1998. Economic cost models of scientific scholarly journals. ICSU Press workshop, Keble College, Oxford UK, March to April 1998 [Available at: <http://www.bodley.ox.ac.uk/icsu/kingppr.htm>]

Kingma, B. R. 2001. Electronic journal publishing in mathematics. *The Bottom Line* Vol. 14 (2) pp. 60-64

McCabe, M.J. 1999. The impact of publisher mergers on journal prices: An update. *ARL* 207, Dec. 1999 [Available at: <http://www.arl.org/newsltr/207/jrnprices.html>]

O'Connor, S. 2000. Economic and intellectual value in existing and new paradigms of electronic scholarly communications *Library Hi Tech* Vol. 18 (1) pp. 37-45

Odlyzko, A.. 2002. The economics of electronic journals. *First Monday* Vol. 2 (8) 1997 [Available at: [http://www.firstmonday.dk/issues/issue2\\_8/odlyzko/](http://www.firstmonday.dk/issues/issue2_8/odlyzko/)]

### 3.4 ELECTRONIC PUBLISHING, LEGAL ISSUES

Case, M.M., Adler, P.S. 2002. Promoting open access: Developing new strategies for managing copyright and intellectual property *ARL* 220, Febr. 2002 [Available at: <http://www.arl.org/newsltr/220/access.html>]

### 3.5 ELECTRONIC PUBLISHING, ARCHIVING

Beebe, L., Meyers, B. 1999. The unsettled state of archiving. *The Journal of Electronic Publishing*, vol. 4(4) [Available at: <http://www.press.umich.edu/jep/04-04/beebe.html>]

Hodge, G., Carroll, C. 1999. Digital electronic archiving: The state of the art and the state of the practice. A report sponsored by: International Council for Scientific and Technical Information Policy Committee and CENDI

### 3.6 IMPACT FACTORS, CITATION INDEXING

Amin, M., Mabe, M. 2000. Impact factors: use and abuse. Perspectives in Publishing October 2000 (occasional newsletter, Elsevier) [Available at: <http://www.elsevier.com>]

Harter, S. P. 1996. The impact of electronic journals on scholarly communication: A citation analysis. *The Public-Access Computer Systems Review* [Available at: <http://www.neci.nec.com/~lawrence/papers/aci-computer99/aci-computer99.pdf>]

Harter, S.P., Kim, H.J. 1996. Electronic journals and scholarly communication: A citation and reference study. *Proceedings of the Midyear Meeting of the American Society for Information Science*, San Diego, CA, May 20-22 1996. [Available at: <http://info.lib.uh.edu/pr/v7/n5/hart7n5.html>]

Lawrence, S., Giles, C.L., Bollacker, K. 1999. Digital libraries and autonomous citation indexing. *IEEE Computer*, vol. 32(6), pp. 67-91 [Available at: <http://ezinfo.ucs.indiana.edu/~harter/harter-asis96midyear.html>]

### 3.7 USAGE STATISTICS

Luther, J. 2000. White paper on electronic journal usage statistics. *The Journal of Electronic Publishing*, Reprint [Available at: <http://www.press.umich.edu/jep/06-03/luther.html>]

Odlyzko, A. 2001. The rapid evolution of scholarly communication. *Learned Publishing*, vol 15(1) pp. 7-19 [Available at: <http://www.alpsp.org.uk/journal.htm>]

### 3.8 JOURNALS

Annual Review of Information Science and Technology (ARIST)  
<http://www.asis.org/Publications/ARIST/>

ARL A Bimonthly Report on Research Library Issues and Actions from ARL, CNI and SPARC  
<http://www.arl.org/newsltr/osc.html>

First Monday <http://www.firstmonday.dk/index.html>

Free Online Scholarship Newsletter <http://www.earlham.edu/%7Eepeters/fos/>

Journal of Digital Information <http://jodi.ecs.soton.ac.uk/>

Journal of Documentation <http://www.emeraldinsight.com/jd.htm>

Journal of Electronic Publishing <http://www.press.umich.edu/jep/>

Journal of Scholarly publishing <http://www.utpjournals.com/jour.ihtml?lp=indexj.html>

Journal of the American Society for Information Science  
<http://www.asis.org/Publications/JASIS/jasis.html>

Library Hi Tech <http://www.emeraldinsight.com/jd.htm>

Serials Review <http://www.elsevier.com/locate/issn/00987913>

### 3.9 PROJECTS, INITIATIVES AND DEBATES

BioMed Central. Source: <http://www.biomedcentral.com/>

Budapest Open Access Initiative ARL 220, Febr. 2002  
<http://www.arl.org/newsltr/220/boai.html>

International Scholarly Communication Alliance  
<http://www.topica.com/lists/fos-forum/read/message.html?mid=903374369&sort=d&start=78>

Los Alamos Physics Archive <http://xxx.lanl.gov/>

Nature hosted online debate on free online scholarship. Web debate. Nature  
<http://www.nature.com/nature/debates/e-access/>

Open Archives Initiative <http://www.openarchives.org/documents/index.html>

Public Library of Science (PLoS) <http://www.publiclibraryofscience.org/>

PubMed Central. An archive of life science journals <http://www.pubmedcentral.nih.gov/>

SPARC, the Scholarly Publishing and Academic Resources Coalition. Declaring  
Independence: A guide to creating community-controlled science journals  
<http://www.arl.org/sparc/home/index.asp?page=0>